



Silica Adsorption Unit for Gas-Conditioning



**Natural Gas Storage
UGS Haidach**

Project: Natural Gas Storage Haidach

In 2007, the underground gas storage (UGS) Haidach was put into operation as a joint venture project of the Röhö-Aufsuchungsgesellschaft (RAG) in Austria with the partners Wingas, and the Russian company Gazexport. The former natural gas field Straßwalchen near Salzburg will have

a capacity of 2.4 billions cubic metre of natural gas. This corresponds app. to a quarter of the Austrian annual consumption of natural gas. Thus the UGS Haidach is the largest gas storage in Austria, and the second largest in Central Europe.

Unit: The Gas Drying

Due to the fact that natural gas in the gas storage always absorbs moisture, and for avoiding corrosion and disposal in the compressor stations and gas pipelines the gas has to be dried. After evaluation of three different processes for gas drying it was finally decided to proceed with the adsorption

technology using Silica-Gel. The natural gas taken from the underground storage Haidach is processed in a Silica Adsorption Drying Unit, i.e. the dew point of water and hydrocarbons is reduced to the values required for the gas grid.

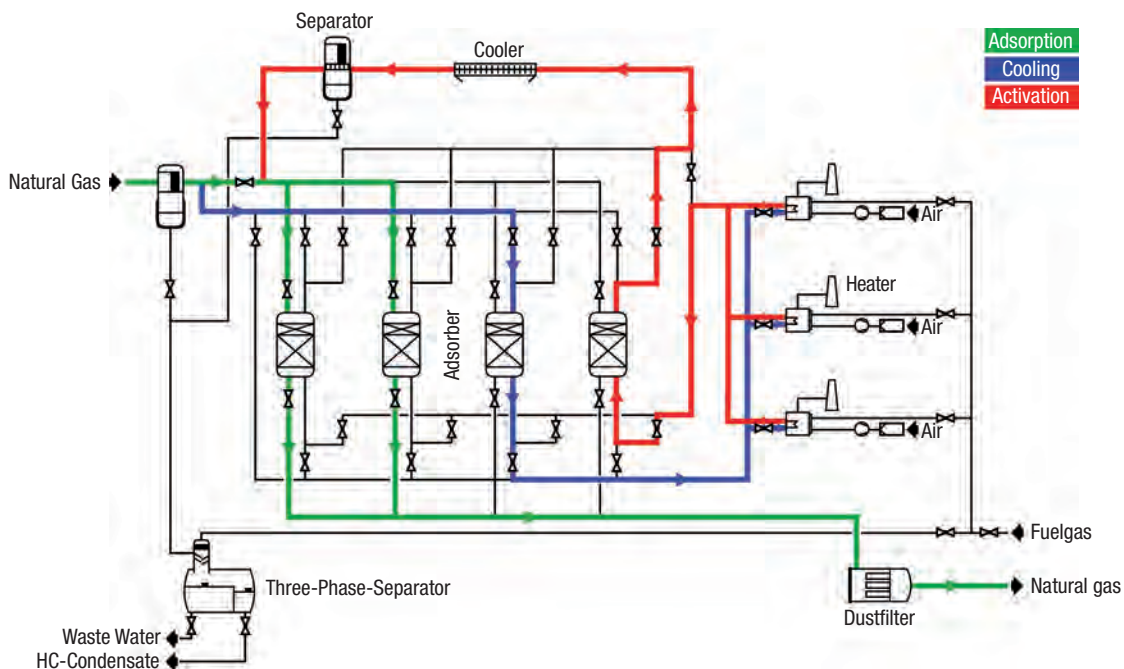

Process: The Silica Adsorption Unit

Two of the four adsorbers are used in parallel for the treatment of the natural gas, while the remaining two are in regeneration mode at the same time.

After removal of existing condensate in the inlet demister, the natural gas flows in downstream direction through the two adsorbers in adsorption mode that are filled with Silica-Gel. By passing the adsorption bed the dew points for water and hydrocarbons are reduced considerably below the requirements. Finally, the natural gas is led through a dust filter and discharged purified into the grid.

A control valve in the main line is used to separate a part flow for regeneration purposes. This particular flow first passes the adsorber to be cooled in downward direction. Subsequently, via the heater that is directly fired with natural gas the regeneration gas stream is heated up to the required regeneration temperature. The hot gas flows through the adsorber to be activated in an upward direction to remove the previously adsorbed hydrocarbons and water.

In the air-cooled heat exchanger the regeneration gas is cooled down to the inlet temperature again. Resulting condensate is removed automatically in the regeneration separator. Then, by returning of the regeneration part flow into the main gas downstream of the control valve no gas losses for the regeneration will occur.

The serial connection of both adsorbers in regeneration mode is most effective to recover and use the heat energy from the adsorbers in cooling phase for the adsorbers to be activated. The energy consumption is minimized.

The existing condensate from the separators is expanded and discharged into a low-pressure 3-phase separator. Any generated flash gas is recovered, combusted and therefore supports the heating of regeneration gas in the direct-fired heater. The operating cost can be minimized, and additional emissions avoided.

Drying by Adsorption:

Medium:	Natural Gas
Capacity:	260,000 Nm ³ /h per each train
Load range:	15,000 to 300,000 Nm ³ /h
Pressure (operation):	44 to 90 barg
Temperature (at inlet):	20 to 45 °C
Pressure drop:	app. 3 bar at 70 barg and typical gas composition

Outlet condition:

Water-Dewpoint:	< -8 °C at 70 barg
Hydrocarbon-Dewpoint:	< -5 °C at 0 to 90 barg

Technical Data:

Adsorber:	4 pieces, diameter 2,800 mm, cyl. height 7,500 mm Internal insulation with special concrete, thickness: 150 mm
Adsorption agent:	Silica beads type WS and H, 20,000 kg per adsorber
Heater:	direct-fired heater with natural gas and flash gas 3 pieces operating in parallel, output 2.9 MW each
Cooler:	air cooled, thermal capacity: 8 MW, 3 fans, electrical load: 11 kW each
Piping Process gas:	16"/10" 600/900 lbs
Regeneration gas system:	8" 900 lbs
Mechanical design:	pressure: 100 barg, temperature: -27 to 340 °C
Material:	P355NL, P460NL1 (SA-516-70, A612)

Advantages:

Essential advantages of the unit compared to other processes:

- wide range in flow rate: 10 to 110 % of nominal capacity
- great flexibility in the operating pressure
- prompt availability, no start-up period required
- no additives required (e.g. hydrate-inhibitors)
- recovery of flash gases and usage in the regeneration gas heater
- low operation cost over the complete pressure range

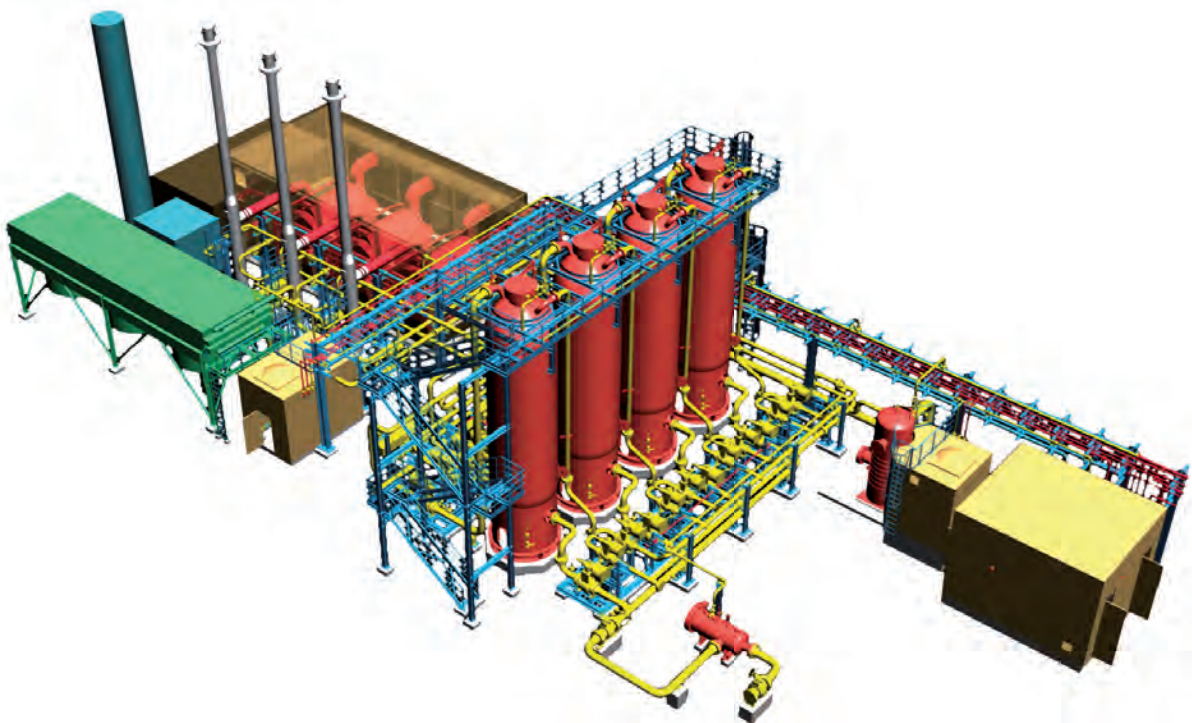

The Company

Silica Verfahrenstechnik GmbH delivers adsorption technology from design to turnkey installation.

Silica provides complete, customer-designed units for a wide range of applications: drying of gases, organic liquids or compressed air, catalytic purification of technical gases and process gases, natural gas treatment as well as waste air purification and solvent recovery. As adsorbent Silica-Gel,

activated alumina, molecular sieves, and activated carbon are at Silica's disposal. Decades of experience and engineering competence in connection with up to date technology guarantee the successful accomplishment of task and project implementation of customer requirements. The reliability and quality of Silica units are best known worldwide.

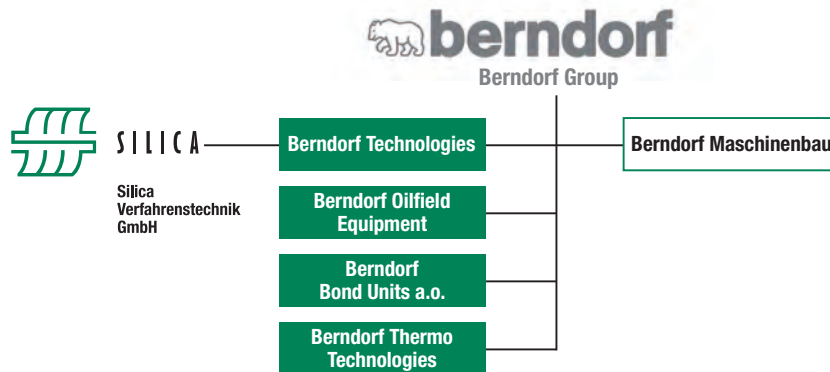

History

80 years ago, the Silica company was founded in Berlin to produce Silica-Gel and to develop its applications. In 1963 the Silica Gel fabrication was sold, and since that time Silica is solely dedicated to engineering and plant construction. In the last 20 years, worldwide more than 500 adsorption units have been delivered, and the number increases by 20 to 30 units per year.

Since 1993 the Austrian Berndorf AG holds 75 percent of the Silica Verfahrenstechnik GmbH that has currently 40 employees at its location in Berlin-Reinickendorf, and an annual turnover of app. 15 to 20 million Euro.

- 1929** Foundation of the German branch of the Silica Gel Corporation, Baltimore
- 1934** Take-over of the German company by the German management
- 1963** Sale of the Silica Gel production facility to the US company Grace Davison
- 1991/93** Transfer into the Silica Verfahrenstechnik GmbH with a 75 % stake of Berndorf AG



SILICA

**Silica
Verfahrenstechnik
GmbH**

Witestraße 24
D-13509 Berlin

Tel. +49 30 435 73-5

Fax +49 30 435 73-300

E-Mail info@silica.de
www.silica.de